

Development and production
of laser and sorting systems

IL 2600 Sorting System



The InnoLas IL 2600 wafer sorting system can automatically sort, split, merge and transfer wafers from any slot / cassette to any other slot / cassette in a six cassette array.

Wafer sizes from 2" to 100mm and 100mm to 200mm can be handled in a single or multi-batch operation without the need of any mechanical adjustments.

The laser mark code read for verification can be located at any position on the front and/or backside of the wafer.

The basic model has one reading unit (OCR, BC412, T7) for reading the laser code on the frontside of the wafer. A second reading unit (OCR, BC412, T7) for reading the code on the backside of the wafer can be mounted as an option.



Development and production of laser and sorting systems

Technical Specifications IL 2600 Series

HANDLING SYSTEM

Wafer sizes:	2", 2.25", 3", 3.25" and 100, 125, 150, 200mm
Wafer transfer:	Robot - double end effector
Wafer alignment:	Opto mechanical aligner
Wafer handling:	Vacuum or edge grip
Number of stations:	6 stations (input/output)
Throughput:	600 wafers/hr (transfer mode) 250 wafers/hr (sort mode)

READING SYSTEM

Fonts:	Dot Matrix (SEMI 5x9, 10x18, 15x23 and 9x17) Barcode (SEMI 412, IBM 412) 2D Code (SEMI T7) Engrave Mode Others on request
Checksum:	SEMI, IBM

STANDARD OPTIONS

- Reading system for wafer front and / or backside
- Barcode hand scanner
- SECS/GEM host software
- Wafer thickness measurement

FACILITY REQUIREMENTS

Electrical:	230V AC / 1P / N / PE / 50Hz / 10A 115V AC / 1P / N / PE / 60Hz / 20A
Communication:	Ethernet RJ45 connector
Vacuum:	-800mbar (23.6Hg) - Festo 8mm OD connection
Weight:	400kg (882 lb) depending on options

CERTIFICATION

CE certified

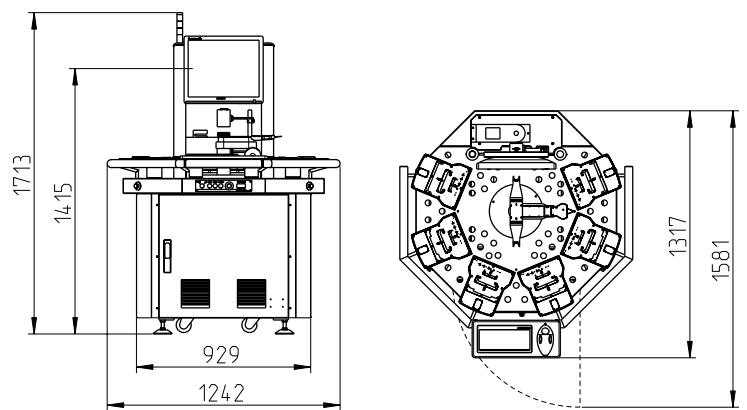
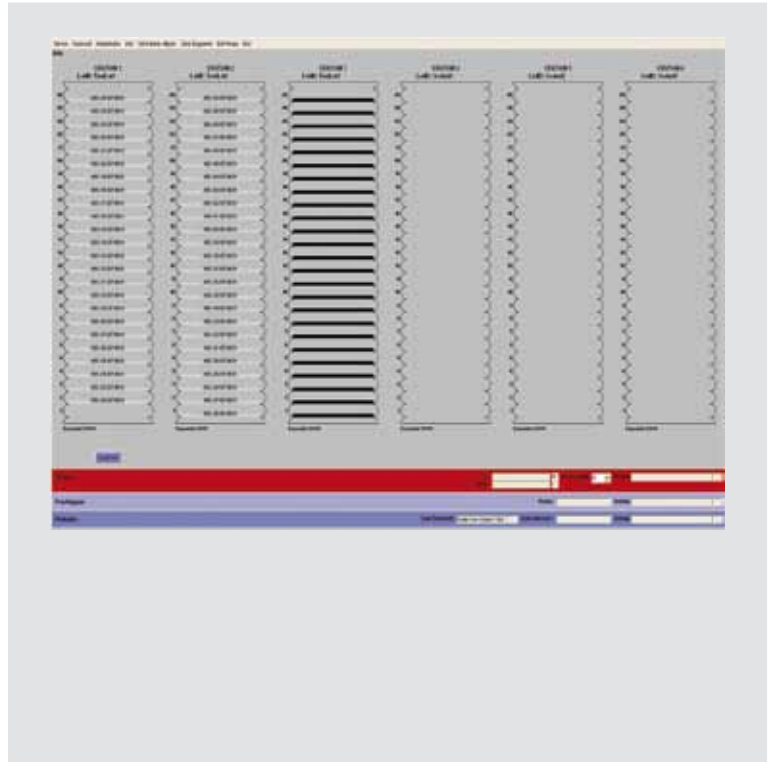

Dimensions in mm